



Item No. \_\_\_\_\_

# C713

## Soft Serve Freezer

C713

Twin Twist

### Features

Offer all the popular soft serve variations from low or non-fat ice creams to custards, yogurt and sorbet. Serve two separate soft serve flavors, or an equal combination of both in a twist.

### Freezing Cylinder

Two, 3.4 quart (3.2 liter).

### Mix Hopper

Two, 20 quart (18.9 liter). Separate hopper refrigeration (SHR) maintains mix below 41°F (5°C) during Auto and Standby modes.

### Indicator Lights

Digital readout displays hours since last brush cleaning to assure product safety. Mix Low light alerts operator to add mix. Audible alarm may be enabled to sound when mix is low. When the Mix Out light flashes, the unit shuts down automatically to prevent damage.

### Touch Screen Controls

Microprocessor touch controls are embedded in durable tempered glass panel. Multiple languages are selectable. Viscosity is continually measured to dispense consistent quality soft serve desserts. Temperatures in the hoppers or freezing cylinders may be displayed at any point of operation, in either Fahrenheit or Celsius. Draw counter allows operator to view number of servings dispensed.

### Standby

During long no-use periods, the standby feature maintains safe product temperatures in the mix hopper and freezing cylinder.

### Two Locking Casters

Front casters have a locking feature for operators to keep equipment in place. The lock can be released to move the equipment for cleaning.

### Door Interlock System

Protects the operator from injury as the beater will not operate without the dispensing door in place.

### Freezer Door

A specially designed thermo-plastic door allows quick ejection of product with a simple movement of the draw handle. Self closing draw handles are standard.



### Integrated Syrup Rail Option

2 room temperature with lids & ladles, 2 heated with syrup pumps

750 N. Blackhawk Blvd. Rockton, Illinois 61072  
800-255-0626  
Phone 815-624-8333 Fax 815-624-8000  
[www.taylor-company.com](http://www.taylor-company.com)  
info@taylor-company.com

ISO 9001:2008  
Registered Firm



Standard 6



LISTED  
SA2650



Selected 50  
Hz. Models

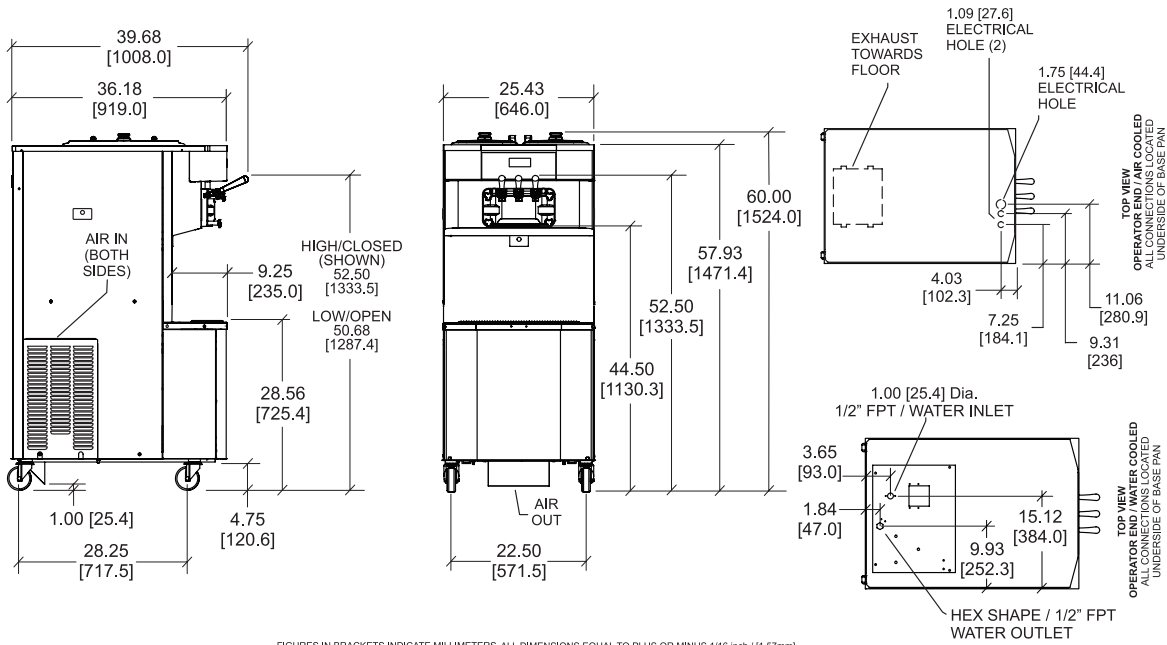

FIGURES IN BRACKETS INDICATE MILLIMETERS. ALL DIMENSIONS EQUAL TO PLUS OR MINUS 1/16 inch / [1.57mm].

Weights	lbs.	kgs.
Net	733	332.5
Crated	810	367.4
Volume	cu. ft.	cu. m.
	67.5	1.91
Dimensions	in.	mm.
Width	25-7/16	646
Depth	36-3/16	919
Height	60	1524
Floor Clearance	4-3/4	121

\*Mounted on standard casters.

Electrical	Maximum Fuse Size		Minimum Circuit Ampacity		Poles (P) Wires (W)
	Left	Right	Left	Right	
208-230/60/1 Air	35	35	25	23	2P 3W
208-230/60/1 Air, Syrup	35	35	26	23	2P 3W
208-230/60/1 Water	35	35	25	23	3P 4W
208-230/60/3 Air	25	25	19	17	3P 4W
208-230/60/3 Water	20	20	17	15	3P 4W
220-240/50/1 Water	25	25	21	19	2P 3W
380-415/50/3N~ Air	12	10	9	8	4P 5W

This unit may be manufactured in other electrical characteristics and may have additional regulatory agency approvals. Consult the local Taylor Distributor for other electrical characteristics and agency approvals based on specific electrical and country requirements.  
**(For exact electrical information and approval marks, always refer to the data label of the unit.)**

**Continuing research results in steady improvements; therefore, these specifications are subject to change without notice.**

**Bidding Specs**

Electrical: Volt \_\_\_\_\_ Hz \_\_\_\_\_ ph \_\_\_\_\_  
 Neutral: Yes No      Cooling: Air Water NA

Options: \_\_\_\_\_

**Specifications**

**Electrical**

Two dedicated electrical connection is required. See the Electrical chart for the proper electrical requirements. Manufactured to be permanently connected. Consult your local Taylor distributor for cord & receptacle specifications as local codes allow.

**Beater Motor**

Two, 1.5 HP.

**Refrigeration System**

Two, 9,500 BTU/hr. R404A. Separate Hopper Refrigeration (SHR), One, 400 BTU/hr. R134a. (BTUs may vary depending on compressor used.)

**Air Cooled**

Minimum 3" (76 mm) around all sides. Install the deflector provided to prevent recirculation of warm air. Minimum air clearances must be met to assure adequate air flow for optimum performance.

**Water Cooled**

Water inlet and drain connections under side of base 1/2" FPT.

**Options**

- Cone Dispenser
- Drain Adaptor (for ease of rinsing & cleaning)
- Draw Valve Lock Kit
- Faucet
- Hopper Locks
- Hopper Agitators
- Panel Spinner
- Syrup Rail (Integrated)
- Syrup Rail Kit (side mount)

**Authorized Taylor Distributor**

**TAYLOR®**  
 750 N. Blackhawk Blvd.  
 Rockton, Illinois 61072  
[www.taylor-company.com](http://www.taylor-company.com)